



ColorBurst 6

The original architectural LED spotlight with intelligent color light



ColorBurst 6

The original architectural LED spotlight with intelligent color light

ColorBurst 6 combines the classical look of a round, 152 mm (6 in) spotlight with all the benefits of intelligent LED technology. Enclosed in a rugged, die-cast aluminium housing, this compact spotlighting and wall-washing Luminaire projects rich, saturated colors and color-changing effects both indoors and outdoors. Enclosed wiring gives ColorBurst 6 a neat appearance and optimum positioning. The housing is equipped with a three-screw accessory ring to affix spread lenses, egg-crate louvers, and other attachments.

- Two beam angles — Available with a frosted tempered glass lens for a soft-edge beam of light (21° beam angle), or a clear lens for extended light projection (10° beam angle).
- High-intensity, energy-efficient light — Each ColorBurst 6 Luminaire outputs over 500 lumens while consuming just 25 W at full intensity.
- Flexible positioning and aiming — A 350° locking base swivel and 350° locking Luminaire rotation offer a versatile range of light positioning.
- Full range of accessories — Designed specifically for ColorBurst, accessories provide additional options for controlling and dispersing light. Top hats, half top hats, egg crate louvers, barn doors, and glass spread lenses attach easily to an integrated accessory attachment ring on the ColorBurst 6 housing.
- Versatile mounting options — ColorBurst 6 mounts to standard junction boxes or to a specially designed mounting base, available separately. With the optional mounting base, ColorBurst 6 can be freestanding on a floor. Each mounting base comes with a native 18.3 m (60 ft) power and data cable to minimize wiring.
- On-board temperature monitoring — A compensation circuit prevents damage to the Luminaire if operating temperatures rise to unsafe levels. An auto-cycling feature automatically restores normal operation after 30 minutes.
- Industry-leading controls — ColorBurst 6 Luminaires work seamlessly with the complete line of Philips Color Kinetics controllers, including ColorDial Pro, iPlayer 3, and Light System Manager, as well as third-party controllers.



Outdoor Rated

Fully sealed for maximum Luminaire life and IP66-rated for outdoor applications. Rugged, die-cast aluminium housing is available in white or black.

Dynamic and Inviting Interiors with ColorBurst 6

Although ColorBurst 6 is designed with a fully-sealed die-cast aluminium housing for use in exterior and wet locations, its small footprint, focused beam, and ease of installation make it the perfect choice for indoor spotlighting and accent lighting as well.

Spotlight on the Folsom Library

The Richard G. Folsom Library on the Troy, New York, campus of Rensselaer Polytechnic Institute (RPI) had not been renovated since its opening in 1976. RPI recognized the need for a refurbishment that would make its main library more user-friendly and inspire and attract students, researchers, and others.

The lighting designer drafted a creative plan with an emphasis on color-changing accent lighting and spotlighting. To make the library more open and inviting, light show colors were designed to dynamically interact with the changing climate of upstate New York, displaying warm colors during the cold winter months, cool colors in the summer, greens in the spring, and orange colors in the fall.

The library uses a variety of Philips color-changing LED lighting Luminaires throughout — to lend color to computer hubs and work areas, for example. ColorBurst Luminaires are used to accentuate an inverted world map, specially designed for the renovation, which provides a dramatic backdrop for the library's circulation desk.

A single Philips Color Kinetics DMX controller gives library staff complete control over all of the lighting Luminaires and light shows, both static and dynamic, throughout the library. In addition to providing an inviting atmosphere year-round, Philips LED lighting benefits the library through low energy consumption and minimal maintenance costs as compared with the traditional lighting sources formerly in place.



Photography: Kris Qua

Photometrics

Photometric data is based on test results from an independent NIST traceable testing lab. IES data is available at www.colorkinetics.com/support/ies.

ColorBurst 6 10° clear lens

LED	Lumens	Efficacy
RGB	563	22.5

Polar Candela Distribution

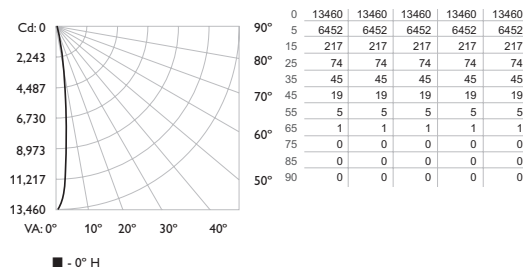

Illuminance at Distance

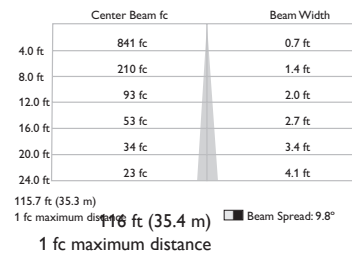

Zonal Lumen

0-30	513.8	91.3%	91.3%
0-40	542.6	96.4%	96.4%
0-60	561.9	99.8%	99.9%
60-90	0.7	0.1%	0.1%
0-90	562.6	99.9%	100%
90-180	0	0%	0%
0-180	562.6	99.9%	100%
Total Efficiency: 99.9%			

Coefficients Of Utilization - Zonal Cavity Method

		Effective Floor Cavity Reflectance: 20%																																												
RCC %:	80	70											50											30											10											0
RW %:	70	50	30	0	70	50	30	0	50	30	20	50	30	20	50	30	20	50	30	20	0																									
RCR:	0	1.19	1.19	1.19	1.16	1.16	1.16	1.00	1.11	1.11	1.11	1.06	1.06	1.06	1.02	1.02	1.02	1.00	1.00	1.00	0.98																									
	1	1.16	1.14	1.12	1.11	1.13	1.12	1.10	0.98	1.08	1.07	1.06	1.04	1.03	1.03	1.01	1.00	0.98	0.97	0.96	0.95																									
	2	1.13	1.09	1.07	1.05	1.11	1.08	1.06	0.96	1.05	1.03	1.01	1.02	1.01	0.99	0.99	0.98	0.97	0.96	0.95	0.94																									
	3	1.10	1.06	1.03	1.00	1.08	1.05	1.02	0.95	1.02	1.00	0.98	1.00	0.98	0.97	0.96	0.95	0.94	0.93	0.92	0.91																									
	4	1.07	1.03	1.00	0.97	1.06	1.02	0.99	0.93	1.00	0.97	0.96	0.98	0.96	0.94	0.97	0.95	0.93	0.92	0.91	0.90																									
	5	1.05	1.00	0.97	0.94	1.04	0.99	0.96	0.91	0.98	0.95	0.93	0.97	0.94	0.93	0.95	0.93	0.92	0.91	0.90	0.89																									
	6	1.03	0.98	0.95	0.92	1.02	0.97	0.94	0.90	0.96	0.93	0.91	0.95	0.93	0.91	0.94	0.92	0.90	0.89	0.88	0.87																									
	7	1.01	0.96	0.93	0.90	1.00	0.96	0.92	0.89	0.95	0.92	0.90	0.94	0.91	0.89	0.93	0.91	0.89	0.88	0.87	0.86																									
	8	1.00	0.94	0.91	0.89	0.99	0.94	0.91	0.88	0.93	0.90	0.88	0.92	0.90	0.88	0.92	0.89	0.88	0.87	0.86	0.85																									
	9	0.98	0.93	0.90	0.88	0.97	0.93	0.90	0.87	0.92	0.89	0.87	0.91	0.89	0.87	0.91	0.88	0.87	0.86	0.85	0.84																									
	10	0.97	0.92	0.89	0.86	0.96	0.91	0.88	0.86	0.91	0.88	0.86	0.90	0.88	0.86	0.90	0.87	0.86	0.85	0.84	0.83																									

For lux multiply fc by 10.7

ColorBurst 6 21° frosted lens

LED	Lumens	Efficacy
RGB	517	20.7

Polar Candela Distribution

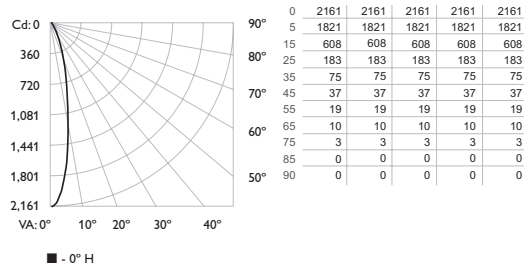

Illuminance at Distance

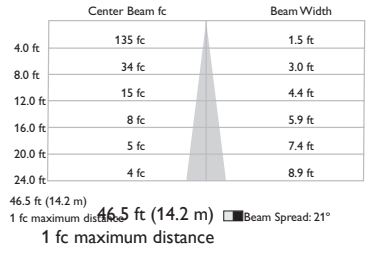

Zonal Lumen

0-30	409.3	79.2%	79.2%
0-40	457.1	88.4%	88.4%
0-60	503.4	97.4%	97.4%
60-90	13.7	2.6%	2.6%
0-90	517.0	100%	100%
90-180	0	0%	0%
0-180	517.0	100%	100%
Total Efficiency: 100%			

Coefficients Of Utilization - Zonal Cavity Method

	Effective Floor Cavity Reflectance: 20%																		
RCC %:	70	50	30	0	70	50	30	0	50	30	20	50	30	20	50	30	20	0	
RW %:	1.19	1.19	1.19	1.19	1.16	1.16	1.16	1.00	1.11	1.11	1.11	1.06	1.06	1.06	1.02	1.02	1.02	1.00	
RCR:	0	1.14	1.11	1.09	1.07	1.12	1.09	1.07	.95	1.05	1.04	1.02	1.02	1.00	.99	.98	.97	.96	.94
	2	1.09	1.05	1.01	.98	1.07	1.03	1.00	.90	1.00	.97	.95	.97	.95	.93	.94	.92	.91	.89
	3	1.04	.99	.94	.91	1.02	.97	.93	.85	.95	.91	.88	.92	.89	.87	.90	.88	.86	.84
	4	1.00	.93	.88	.85	.98	.92	.88	.81	.90	.86	.83	.88	.85	.82	.86	.84	.81	.80
	5	.96	.89	.84	.80	.95	.88	.83	.77	.86	.82	.79	.85	.81	.78	.83	.80	.78	.76
	6	.92	.85	.80	.76	.91	.84	.79	.74	.83	.78	.75	.81	.78	.75	.80	.77	.74	.73
	7	.89	.81	.76	.72	.88	.81	.76	.71	.79	.75	.72	.78	.74	.71	.77	.74	.71	.70
	8	.86	.78	.73	.69	.85	.77	.73	.68	.76	.72	.69	.75	.72	.69	.75	.71	.68	.67
	9	.83	.75	.70	.67	.82	.75	.70	.66	.74	.69	.66	.73	.69	.66	.72	.69	.66	.65
	10	.80	.72	.68	.64	.80	.72	.67	.64	.71	.67	.64	.71	.67	.64	.70	.66	.64	.63

RCC %: Ceiling reflectance percentage, RW %: Wall reflectance percentage, RCR: Room cavity ratio

For lux multiply fc by 10.7

Specifications

Due to continuous improvements and innovations, specifications may change without notice.

Item	Specification	Clear Lens	Frosted Lens
Output	Beam Angle	10°	21°
	Lumens*	563	517
	LED Channels	Red / Green / Blue	
	Mixing Distance	152 mm (6 in) to uniform light	
	Lumen Maintenance†	50,000+ hours L50 @ 50° C (full output)	
Electrical	Input Voltage	24 VDC via PDS-150e or PDS-60	
	Power Consumption	25 W maximum at full output, steady state	
Control	Interface	PDS-150e 24V (DMX / Ethernet) PDS-60 24V (Pre-programmed, or DMX / Ethernet)	
	Control System	Philips full range of controllers, including iPlayer 3, Light System Manager, and ColorDial Pro, or third-party controllers	
Physical	Dimensions (Height x Width x Depth)	208 x 213 x 61 mm (8.2 x 8.4 x 2.4 in)	
	Weight	1.9 kg (4.1 lb)	
	Housing	Die-cast aluminium, black or white powder-coated finish	
	Lens	Clear tempered glass	Frosted tempered glass
	Luminaire Connections	Flying leads on Luminaire Optional 60 ft (18.3 m) power/data cable with Mounting Base	
	Temperature Ranges	-40 to 50 °C (-40 to 122 °F) Operating -20 to 50 °C (-4 to 122 °F) Startup -40 to 80 °C (-40 to 176 °F) Storage	
	Humidity	0 to 95%, non-condensing	
	Maximum Luminaires Per Power / Data Supply	PDS-150e 24V: 6 (3 per port) PDS-60 24V: 2 (1 per port)	
Certification and Safety	Certification	UL/cUL, CE, PSE, C-Tick, SAA	
	Environment	Dry/Damp/Wet Location, IP66	

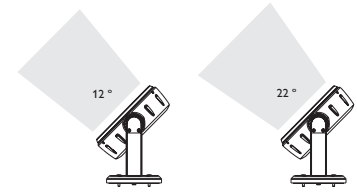

* Lumen measurement complies with IES LM-79-08

† L50 = 50% lumen maintenance (when light output drops below 50% of initial output). Ambient luminaire temperatures specified. Lumen maintenance calculations are based on lifetime prediction graphs supplied by LED source manufacturers. Calculations for white-light LED Luminaires are based on measurements that comply with IES LM-80-08 testing procedures. Refer to www.philipscolorkinetics.com/support/appnotes/lm-80-08.pdf for more information.



CHROMACORE[®] | OPTIBIN[®]
CKTECHNOLOGY | CKTECHNOLOGY

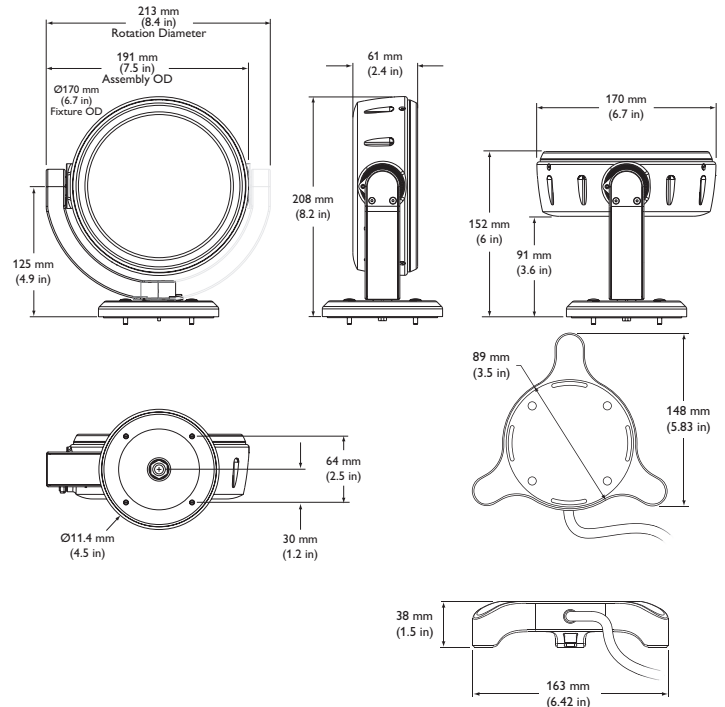

Luminaires and Power / Data Supplies

ColorBurst 6 Luminaires are part of a complete system which includes:

- One or more power / data supplies
- One Mounting Base or junction box per Luminaire
- 18 AWG, 3-conductor stranded copper wire as needed
- Any Philips controller, including ColorDial Pro, Light System Manager, and iPlayer 3, or a third-party DMX controller

Included with the ColorBurst 6

- ColorBurst 6 Luminaire with accessory attachment ring
- Accessory attachment spring
- (4) 8-32 screws for indoor junction box installations
- (4) 10-24 stainless steel screws for outdoor junction box installations
- (4) color-matched screw caps
- 3/32 in hex key wrench
- Junction box gasket
- Installation Instructions

ColorBurst 6 Luminaires
and Mounting Bases

Item	Housing	Type	Item Number	Philips 12NC
ColorBurst 6	White	10° Beam Angle	116-000027-02	910503700735
		21° Beam Angle	116-000027-00	910503700733
	Black	10° Beam Angle	116-000027-03	910503700736
		21° Beam Angle	116-000027-01	910503700734
Mounting Base <i>Includes native 60 ft (15.3 m) power / data cable</i>	White		116-000005-00	910503700111
	Black		116-000005-01	910503700112

Power/Data supplies

PDS-150e 24V	DMX / Ethernet	109-000008-01	910503700092
PDS-60 24V	Pre-programmed	109-000017-00	910503700096
	DMX / Ethernet	109-000017-03	910503700097

Use Item Number when ordering in North America.

Typical ColorBurst 6 installation

For detailed wiring diagrams visit www.philipscolorkinetics.com/support/wiring/l_s_prod.html

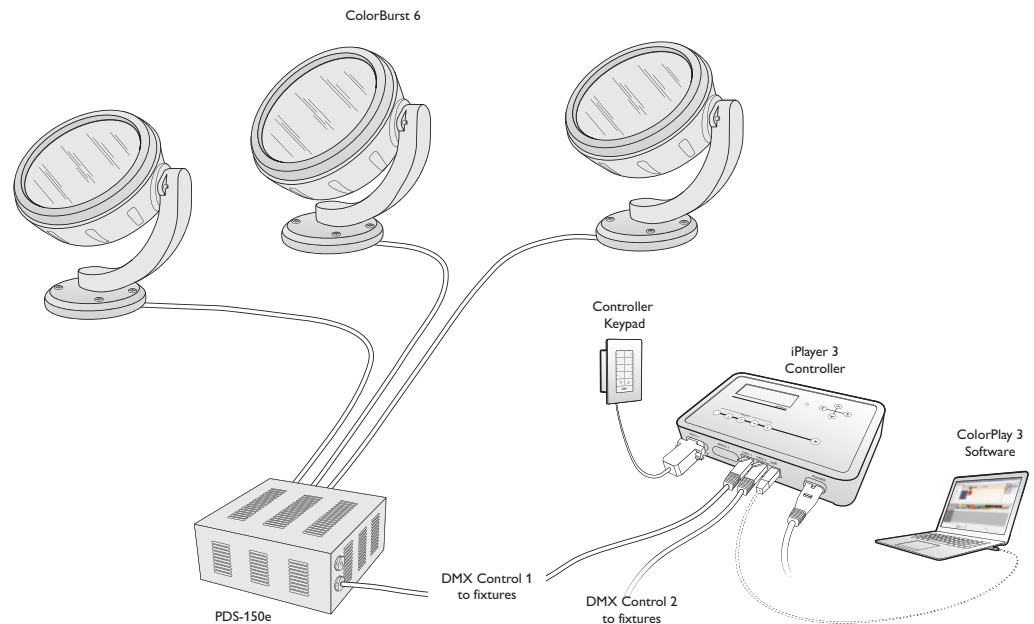

Accessories

Designed specifically for ColorBurst 6 Luminaires, accessories provide additional options for controlling and dispersing light. Accessories attach securely to the ColorBurst 6 accessory attachment ring with the included retention spring and attachment screws. The accessory attachment ring prevents accessories from falling out if the Luminaire is tipped or hung upside down.

Item	Housing Color	Item Number	Philips 12NC
Half Top Hat	White	120-000011-03	—
	Black	120-000011-04	—
Top Hat	White	120-000007-03	—
	Black	120-000007-04	—
Egg Crate Louver	White	120-000017-03	—
	Black	120-000017-04	—
Barndoor	White	120-000021-03	—
	Black	120-000021-04	—
Horizontal Spread Lens	36 / 50°	120-000027-00	—
Horizontal / Vertical Spread Lens	40° / 40°	120-000027-01	—

Installation

ColorBurst 6 projects rich, saturated colors and color-changing effects both indoors and outdoors. A low-voltage Luminaire, ColorBurst 6 is intended for use with the power/data supplies PDS 150e 24V and PDS-60 24V from Philips Color Kinetics. You can mount ColorBurst 6 to the optional Mounting Base, or to a junction box.

✳ Refer to the ColorBurst 6 Installation Instructions for specific warning and caution statements.

Owner / User Responsibilities

It is the responsibility of the contractor, installer, purchaser, owner, and user to install, maintain, and operate ColorBurst 6 Luminaires in such a manner as to comply with all applicable codes, state and local laws, ordinances, and regulations. Consult with the appropriate electrical inspector to ensure compliance.

Installing in Damp or Wet Locations

When installing in damp or wet locations, it is good practice to seal all Luminaires and junction boxes with electronics-grade RTV silicone sealant to ensure that moisture cannot enter or accumulate in wiring compartments, cables, or other electrical parts. You must use suitable outdoor-rated junction boxes when installing in damp or wet locations. Additionally, you must use gaskets, clamps, and other parts required for installation to comply with all applicable local and national codes.

Create a Lighting Design Plan and Layout Grid

1. Determine the appropriate location of each power/data supply in relation to the Luminaires, and of the Luminaires in relation to each other. Refer to the power/data supply's Installation Instructions or Specification Sheet for guidelines on configuring and positioning the power/data supply in relation to the controller.
2. You can install ColorBurst 6 Luminaires to the optional Mounting Base, or to a 102 mm (4 in) round U.S. electrical junction box suitable for your application.
3. You can connect up to six ColorBurst 6 Luminaires to each PDS-150e, or up to two ColorBurst 6 Luminaires to each PDS-60. The Mounting Base includes a native 18.3 m (60 ft) power/data cable. Using 18 AWG, 3-conductor stranded copper wire, you can extend the cabling for each individual Luminaire to a maximum length of 45.7 m (150 ft), as long as the total cable length for each power / data supply does not exceed 121.9 m (400 ft).
4. On an architectural diagram or other diagram that shows the physical layout of the installation, identify the locations of all switches, controllers, power supplies, Luminaires, and cables.
5. Each ColorBurst 6 Luminaire comes pre-programmed with a unique serial number. As you unpack the Luminaires, record the serial numbers in a layout grid (typically a spreadsheet or list) for easy reference and light addressing.
6. Assign each Luminaire to a position in the lighting design plan.
7. To streamline installation and aid in light show programming, you can affix a weatherproof label identifying the order or placement in the installation to an inconspicuous location on each light Luminaire's housing.

Record Luminaire serial numbers

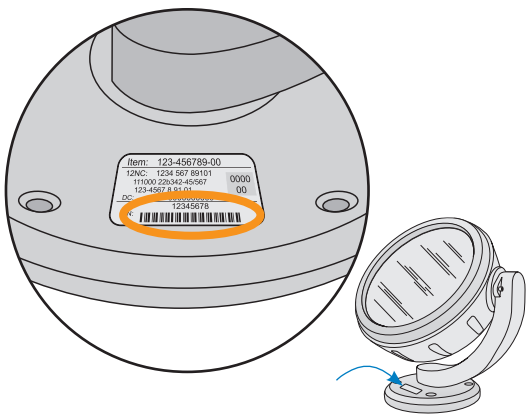

Start the Installation

1. Install all power / data supplies, including any interfaces with controllers. Power / data supplies and external controllers send power and control signals to the Luminaires over a single 3-conductor cable.
2. Ensure that the number of free power / data supply power ports is adequate.
3. Verify that all additional supporting equipment (switches, controllers) is in place.
4. Ensure that all additional parts and tools are available, including:
 - The included 8-32 screws for indoor junction box installations, the included 10-24 stainless steel screws for outdoor installations, or the included M-4 screws if using the Mounting Base
 - The included 3/32 in hex key wrench
 - One Mounting Base per Luminaire, or one 102 mm (4 in) round US electrical junction box per Luminaire, rated for your application, with 89 mm (3.5 in) center-to-center screw holes for attaching the Luminaire's base. (Refer to the junction box manufacturer's literature for additional items required for mounting or sealing.)
 - Medium wire nuts
 - If mounting to a surface using the Mounting Base, #8 screws, suitable for the mounting surface, and lock washers
 - If installing to a junction box, or if extending the native power / data cable included with the Mounting Base, 18 AWG, 3-conductor stranded copper wire as required
 - Conduit as required
 - If installing in a wet or damp location, the included junction box gasket or Mounting Base gasket, and contractor-grade room temperature vulcanizing (RTV) silicone sealant as required

✳ For complete instructions on how to wire the power / data supply, refer to the specific power / data supply's Installation Guide or Specification Sheet. For sample wiring diagrams, visit www.philipscolorkinetics.com/support/wiring/lis_prod.html

✳ If installing in a wet or damp location, you must mount Luminaires to outdoor-rated junction boxes, as described below.



Included with the ColorBurst 6

ColorBurst 6 Luminaire with accessory attachment ring
Accessory attachment spring
(4) 8-32 screws for installing to junction box indoors
(4) 10-24 stainless steel screws for installing to junction box outdoors
(4) color-matched screw caps
3/32 in hex key wrench
Junction box gasket
Installation Instructions

Install the Luminaires

ColorBurst 6 Luminaires can be used freestanding with the Mounting Base, or they can be mounted to a wall, ceiling, or other suitable surface using the Mounting Base or a junction box suitable for your application. In wet or damp locations, ensure that all junction boxes are suitable for the environment and are sealed.

Mounting ColorBurst 6 to a Junction Box

ColorBurst 6 Luminaires are designed for mounting in a 102 mm (4 in) round US electrical junction box, rated for your application, with 89 mm (3.5 in) center-to-center screw holes for attaching the Luminaire's base. If installing in a wet or damp location, mount Luminaires to outdoor-rated junction boxes and seal them with contractor-grade room temperature vulcanizing (RTV) silicone sealant.

1. Mount junction boxes in accordance with the lighting design plan.
2. Pull 18 AWG, 3-conductor stranded copper wire from the junction box to the power / data supply. The maximum cable for an individual Luminaire is 45.7 m (150 ft). The total cable length for each power / data supply cannot exceed 121.9 m (400 ft).
3. If installing in a wet or damp location, run the wire leads from the ColorBurst 6 Luminaire through the included junction box gasket.
4. Trim the Luminaire's 152 mm (6 in) wire leads as necessary, then connect the wire leads to the junction box using medium wire nuts. Connect red to 24 VDC, white to data, and black to common, and neatly tuck wires into the junction box.

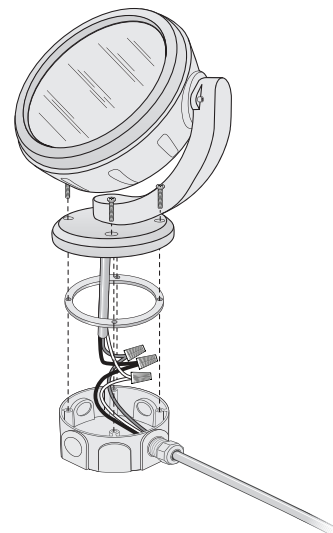

- Using the provided 8-32 screws for indoor installations, or the provided 10-24 stainless steel screws for outdoor installations, attach the Luminaire canopy to the junction box. If using the junction box gasket, ensure that it is compressed evenly.
- Cover the screw heads with the included color-matched screw caps.
- Repeat steps 2 through 6 for each Luminaire in the installation.
- If installing in a wet or damp location, seal all junction boxes with contractor-grade RTV silicone sealant. Use gaskets, clamps, and other parts and fittings required to comply with local outdoor wiring codes.

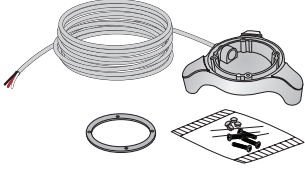

Included with the Mounting Base

Mounting Base with native 60 ft (18.3 m) power / data cable
Gasket

(4) M-4 screws with color-matched screw caps to attach ColorBurst 6 Luminaire to the Mounting Base

(3) Snap-in stem bumpers for freestanding indoor installations

(3) Leg covers

Installation Instructions

Mounting ColorBurst 6 to a Mounting Base

ColorBurst 6 Luminaires can be used freestanding with the Mounting Base, or they can be mounted to a wall, ceiling, or other suitable surface. Snap-in stem bumpers protect floors or other finished surfaces in freestanding indoor applications. The native 18.3 m (60 ft) power/data cable is sealed to create a water-tight junction when used with the included gasket.

- Determine the Luminaire location as specified in the lighting design plan. Ensure that the mounting location is free of debris, and that the Mounting Base sits flush to the mounting surface.
- If installing in a wet or damp location, run the wire leads from the ColorBurst 6 Luminaire through the included gasket.
- Connect Luminaire wire leads to the Mounting Base leads using medium wire nuts. Connect red to red, white to white, and black to black.
- Insert the included M-4 screws through the Luminaire canopy and, if applicable, the gasket, and into the Mounting Base. Tighten the screws. Cover the screw heads with the included color-matched screw caps.
- For freestanding applications, press the included snap-in stem bumpers into the mounting holes on the bottom of each foot of the Mounting Base.
- If mounting to a surface, insert #8 screws suitable for the mounting surface (not included) through the holes in the bottom of each foot of the Mounting Base. Use lock washers to prevent the screws from loosening.
- Press the included leg covers into the opening on the top of each leg of the Mounting Base for a clean, finished look.

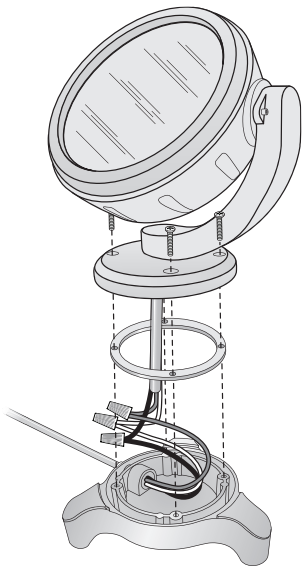

8. Pull the native 18.3 m (60 ft) Luminaire cable to a power/data supply. If necessary, you can extend the cable using 18 AWG, 3-conductor stranded copper wire to a maximum length of 45.7 m (150 ft). The total cable length for each power/data supply cannot exceed 121.9 m (400 ft).
9. Repeat steps 1 through 8 for each Luminaire in the installation.

Make Power Connections

Make sure the power is OFF before mounting and connecting ColorBurst 6 Luminaires.

1. Pull each Luminaire cable through a knockout in the side of the power/data supply.
2. Connect line, common, ground, and data to a provided connector, then snap the connector into the connector terminal inside the power/data supply housing.

Luminaire cable dimensions

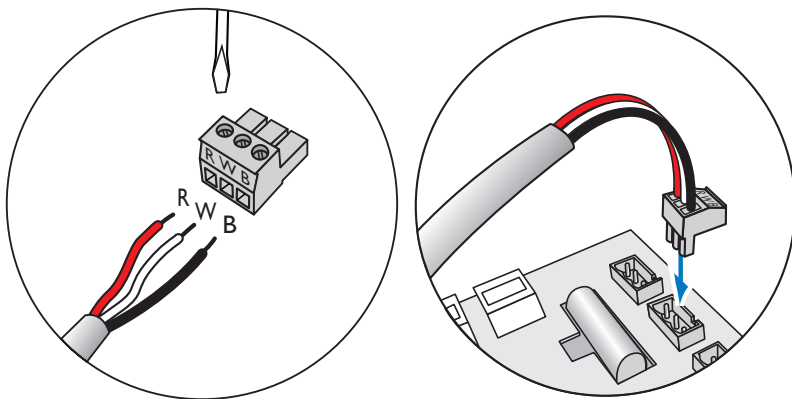
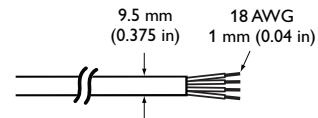

3. Using wire nuts, connect the green ground wire from each Luminaire cable to the earth ground on the power/data supply,

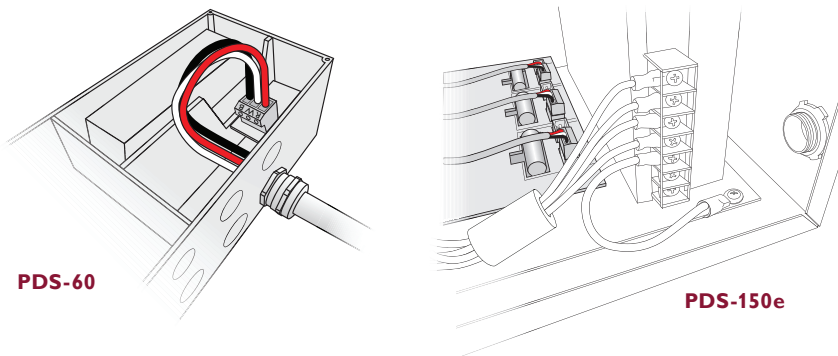

4. Repeat for each power/data supply in your installation.

Install ColorBurst 6 Accessories and Spread Lenses (Optional)

ColorBurst 6 accessories and spread lenses, available separately, attach securely to the Luminaire's accessory attachment ring, which prevents accessories from falling out if the Luminaire is tipped or hung upside down. The included retention spring holds spread lenses flush against the Luminaire housing.

1. Using the included 3/32 in hex key wrench, remove the three screws that secure the accessory attachment ring to the Luminaire housing.

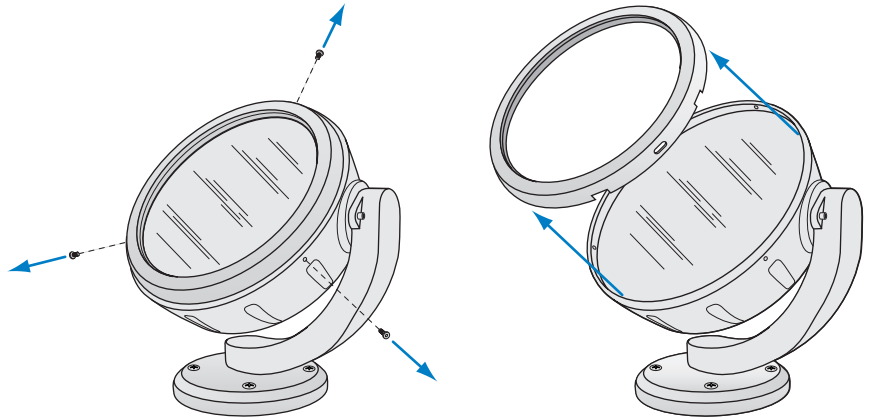
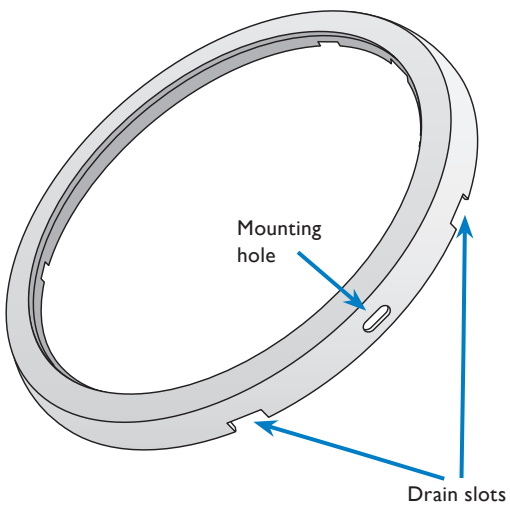

2. If installing an accessory, place it into the front of the Luminaire housing. If installing a spread lens, place it into the accessory ring, and secure it with the retention spring.
3. Align the holes on the accessory ring with the screw holes on the Luminaire housing, ensuring that the drain features align. Replace the attachment screws.

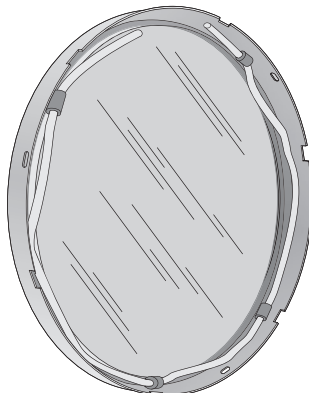
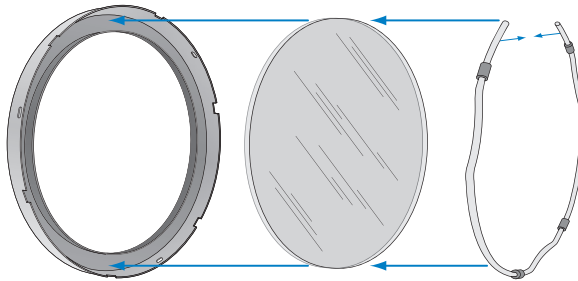

Address and Configure the Luminaires

Make sure the power is ON before addressing and configuring Luminaires.

Each ColorBurst 6 Luminaire uses three sequential DMX channels or addresses, one for red, one for green, and one for blue. ColorBurst 6 Luminaires come factory-addressed to DMX channels 1 (red), 2 (green), and 3 (blue).

For lighting designs where Luminaires work in unison, all Luminaires can be assigned the same DMX addresses. Changes to the default addresses are not necessary, but if lights were previously readdressed for use in other installations, you must reset them. For light show designs that show different colors on different Luminaires, you must assign unique DMX addresses to your Luminaires and sort them in a useful order.

- In Ethernet installations, you can address and configure your Luminaires using QuickPlay Pro with a computer connected to your lighting installation's network. QuickPlay Pro can automatically discover all of your Luminaires, controllers, and power/data supplies for quick configuration.
- In DMX installations, you can address and configure your Luminaires using QuickPlay Pro with iPlayer 3 or SmartJack Pro. You can manually enter Luminaire serial numbers, or you can import a spreadsheet listing each Luminaire's serial number and starting DMX address.

For complete details on addressing and configuring Luminaires, controllers, and power/data supplies with QuickPlay Pro, refer to the *Addressing and Configuration Guide*, which you can view or download at www.philipscolorkinetics.com/support/addressing.

✳ You can download QuickPlay Pro from www.philipscolorkinetics.com/support/addressing/

✳ You will need the layout grid that you created when you recorded the serial numbers of the light Luminaires in your installation.

Aim and Lock the Luminaires

Make sure power is ON before aiming Luminaires.

ColorBurst has a rotating base and pivot, allowing for 350° rotation both vertically and horizontally.

✳ Do not look directly into the Luminaire when aiming and locking.

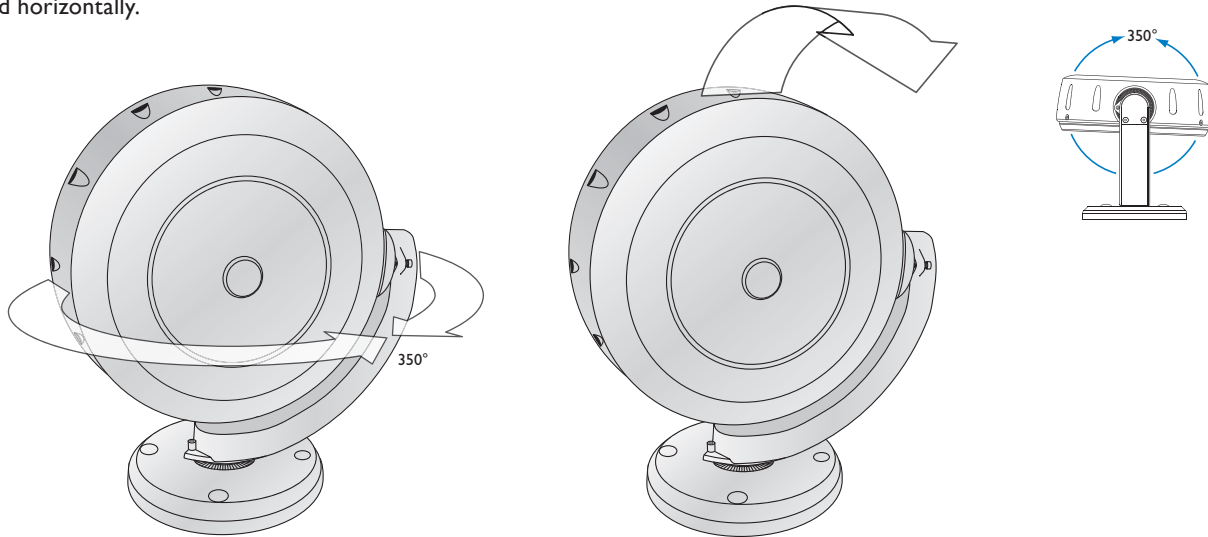

1. To pivot the Luminaire, loosen the pivot set screw using the provided 3/32 in hex key wrench, point the Luminaire as desired, and tighten the set screw to hold the Luminaire in position.

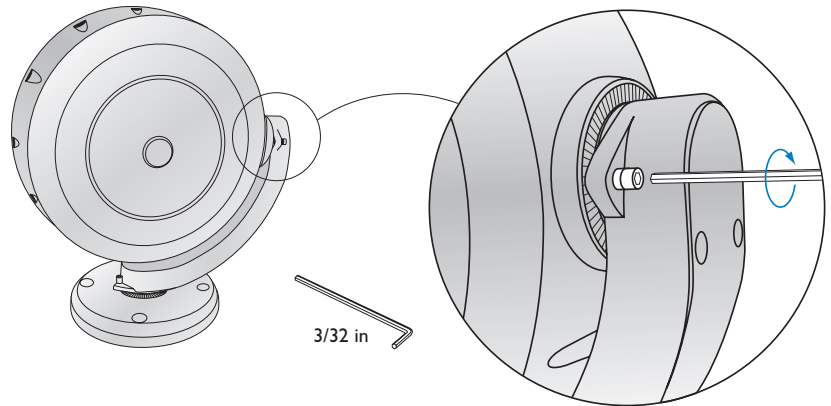

2. To rotate the Luminaire, loosen the base set screw using the provided 3/32 in hex key wrench, rotate the Luminaire to the desired position, and tighten the set screw to lock the Luminaire in position.

Copyright © 2017 Philips Lighting Holding B.V. All rights reserved. Chromacore, Chromasic, CK, the CK logo, Color Kinetics, the Color Kinetics logo, ColorBlast, ColorBlaze, ColorBurst, eW Fuse, ColorGraze, ColorPlay, ColorReach, iW Reach, eW Reach, DIMand, EssentialWhite, eW, EvenBalance, iColor, iColor Cove, IntelliWhite, iW, iPlayer, Optibin, Powercore and PureGlow are either registered trademarks or trademarks of Philips Lighting Holding B.V. in the United States and/or other countries. All other brand or product names are trademarks or registered trademarks of their respective owners. Due to continuous improvements and innovations, specifications may change without notice.

Cover Photo: Ben Franklin Bridge, courtesy of Carlton Read

DAS-000043-00 R04 29 Dec 2017



Philips Color Kinetics
3 Burlington Woods Drive
Burlington, Massachusetts 01803 USA
Tel 888.385.5742
Tel 617.423.9999
Fax 617.423.9998
www.colorkinetics.com