

COLORBLAST 12 TR



The ColorBlast® 12 TR fixture is a Chromacore®-based product designed specifically for stage and set lighting applications. The fixture features a pivoting bezel design that allows for replacement of the lens. Combined with the included clear and soft focus tempered glass lenses, the fixture is immediately expandable between soft-edge wash lighting and extended beam projection. Power and data are provided by an industry-standard 4-pin XLR connector included with the fixture.

Because the stage and set environment can be taxing on equipment, ColorBlast 12 TR also features an elastomeric protection sleeve mounted around the lens area. The sleeve protects the fixture and the lens from the rigors of multiple setups and tear-downs.

Designed to quickly aim the fixture without the need of special tools, ColorBlast 12 TR features a locking, industrial grade constant torque hinge. The pre-assembled mounting base allows the unit to be set on the ground, mounted to a weighted base, or mated to a C-clamp for truss mount applications. The fixture also includes a bracket for easy mounting of safety tethers and carabiner clips. ColorBlast 12 TR also features on-board temperature monitoring. If operating temperatures rise to unsafe levels, a compensation circuit is triggered and operation is interrupted causing the lights to turn a dull red. After 30 minutes, the lights will auto-cycle and return to full intensity.

ColorBlast 12 TR is DMX512-compatible and can be controlled by a Color Kinetics controller or any third-party DMX controller. The PDS-750 TR power supply is an ideal match for stage and set applications. It features on-board addressing, stand alone operation capability and a rugged design ideal for the demanding entertainment environment.

COLORBLAST 12 TR SPECIFICATIONS

COLOR RANGE	16.7 million (24-bit) additive RGB colors; continuously variable intensity
SOURCE	36 High intensity RGB LEDs
BEAM ANGLE	23° ground lens, 10° clear lens
HOUSING	Die Cast Aluminum in black powdercoat finish
LENSES	Soft-focus tempered glass or clear tempered glass
CONNECTORS	6-foot (1.83 m) Unified power and data cable with 4-pin XLR connector
LISTINGS	UL/cUL, CE

COMMUNICATION SPECIFICATIONS

DATA INTERFACE	Color Kinetics data interface system
CONTROL	Color Kinetics full line of controllers or other DMX512 (RS485) sources

ELECTRICAL SPECIFICATIONS

POWER REQUIREMENT	24VDC
POWER CONSUMPTION	50W Max. at full intensity (full RGB)
POWER SUPPLY	PDS-750 TR (ITEM# 109-000019-00)

ENVIRONMENTAL SPECIFICATIONS

TEMPERATURE RANGE	-40°F to 122°F (-40°C to 50°C) operating temperature -4°F to 122°F (-20°C to 50°C) starting temperature
--------------------------	--

LED SOURCE LIFE

In traditional lamp sources, lifetime is defined as the point at which 50% of the lamps fail. This is also termed Mean Time Between Failure [MTBF]. LEDs are semiconductor devices and have a much longer MTBF than conventional sources. However, MTBF is not the only consideration in determining useful life. Color Kinetics uses the concept of useful light output for rating source lifetimes. Like traditional sources, LED output degrades over time (lumen depreciation) and this is the metric for SSL lifetime.

LED lumen depreciation is affected by numerous environmental conditions such as ambient temperature, humidity and ventilation. Lumen depreciation is also affected by means of control, thermal management, current levels, and a host of other electrical design considerations. Color Kinetics systems are expertly engineered to optimize LED life when used under normal operating conditions. Lumen depreciation information is based on LED manufacturers' source life data as well as other third party testing. Low temperatures and controlled effects have a beneficial effect on lumen depreciation. Overall system lifetime could vary substantially based on usage and the environment in which the system is installed.

Temperature and effects will affect lifetime. Color Kinetics rates product lifetime using lumen depreciation to 50% of original light output. When the fixture is running at room temperature using a color wash effect, the range of lifetime is in the range of 80,000-100,000 hours. This is LED manufacturers' test data. High output is defined as any LED device that is 1/2 watt or above. For more detailed information on source life, please see www.colorkinetics.com/lifetime.

CHROMACORE®
BY COLOR KINETICS

OPTIBIN®
BY COLOR KINETICS



ITEM# 116-000019-00

This product is protected by one or more of the following patents: U.S. Patent Nos. 6,016,038, 6,150,774 and other patents listed at <http://colorkinetics.com/patents/>. Other patents pending.

©2005-2006 Color Kinetics Incorporated. All rights reserved. Chromacore, Chromasic, Color Kinetics, the Color Kinetics logo, ColorBlast, ColorBlaze, ColorBurst, ColorCast, ColorPlay, ColorScape, Direct Light, iColor, iColor Cove, iPlayer, Optibin, Powercore, QuickPlay, Sauce, the Sauce logo, and Smartjuice are registered trademarks and DIMand, EssentialWhite, eW, IntelliWhite, iW, and Light Without Limits are trademarks of Color Kinetics Incorporated.

All other brand or product names are trademarks or registered trademarks of their respective owners.

BR0202 Rev 01

Specifications subject to change without notice. Refer to www.colorkinetics.com for the most recent data sheet versions.

COLORBLAST 12 TR - CLEAR LENS

PHOTOMETRIC PERFORMANCE

Photometric data is based on test results from an independent testing lab.

SOURCE SPECIFICATIONS

Optics: Tempered clear glass
 Source: 36 LEDs (12 Red, 12 Green, 12 Blue)
 Beam Angle: 10°
 Distribution: Symmetric direct illumination

ILLUMINANCE DISTRIBUTION

2.1 22.6	3.4 36.6	4.3 46.3	3.8 40.9	2.8 30.1	1.9 20.5	6.0'/2.0m
2.9 31.2	8.7 93.6	14.1 151.8	10.3 110.9	4.5 48.4	2.4 25.8	5.0'/1.5m
3.7 39.8	27.4 294.9	53.9 580.2	37.1 399.3	10.0 107.6	3.0 32.3	4.0'/1.2m
3.7 39.8	28.5 306.8	72.9 784.7	72.6 781.5	28.2 303.5	3.6 38.8	3.0'/1.0m
2.9 31.2	10.5 113.0	38.6 415.5	55.4 596.3	28.0 301.4	3.7 39.8	2.0'/0.6m
2.4 25.8	4.5 48.4	11.1 119.5	15.4 165.8	9.3 100.1	2.8 30.1	1.0'/0.3m
3.0'/1.0m		0'/0m		3.0'/1.0m		

Units: Footcandles (top)/Lux (bottom)
 10.8 lux = 1 fc
 Measured on: All, reflectance model 80/50/20%
 Distance from surface: Bottom of grid, 3' (1.0 m) from surface, light at a 45° angle off horizontal

CANDLE POWER DISTRIBUTION

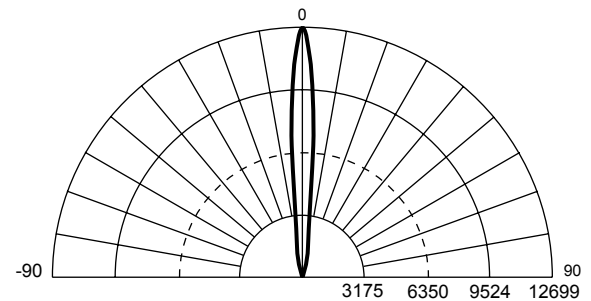

Measured on: White
 Beam center: 12699 cd
 Thin dashed lined: Indicates 50% of peak
 Multipliers: 0.32 Red, 0.53 Green, 0.17 Blue

ILLUMINANCE

COLOR	3'	6'	9'	15'
	1m	2m	3m	5m
WHITE	1415.0	353.0	157.0	56.5
	15231.1	3799.7	1689.9	608.2
RED	452.8	113.0	50.2	18.1
	4873.9	1215.9	540.8	194.6
GREEN	750.0	187.1	83.2	29.9
	8072.5	2013.8	895.7	322.3
BLUE	240.6	60.0	26.7	9.6
	2589.3	645.9	287.3	103.4

Measured in Footcandles (top)/Lux (bottom) on axis.
 Measured on: All, reflectance 0.

LIGHT OUTPUT

COLOR	TOTAL OUTPUT (lumens)	POWER (Watts)	EFFICACY (Lm/w)
WHITE	642	48.2	13.3
RED	205.4	16.6	12.4
GREEN	340.3	16.6	20.5
BLUE	109.1	16.6	6.6

COLORBLAST 12 TR - GROUND LENS

PHOTOMETRIC PERFORMANCE

Photometric data is based on test results from an independent testing lab.

Optics: Soft-focus tempered glass diffuser
 Source: 36 LEDs (12 Red, 12 Green, 12 Blue)
 Beam Angle: 23 degrees
 Distribution: Symmetric direct illumination

ILLUMINANCE DISTRIBUTION

3.3 35.5	5.2 56.0	6.4 68.9	5.9 63.5	4.3 46.3	2.8 30.1	6.0' / 2.0m
4.6 49.5	9.7 104.4	14.0 150.7	11.9 128.1	7.0 75.3	3.8 40.9	5.0' / 1.5m
6.0 64.6	17.5 188.4	29.0 312.2	24.5 263.7	12.0 129.2	4.9 52.7	4.0' / 1.2m
6.3 67.8	21.0 226.0	39.9 429.5	38.1 410.1	18.9 203.4	6.1 65.7	3.0' / 1.0m
5.0 53.8	15.1 162.5	32.2 346.6	36.2 389.7	20.0 215.3	6.1 65.7	2.0' / 0.6m
3.3 35.5	7.6 81.8	16.0 172.2	19.9 214.2	12.5 134.6	4.4 47.4	1.0' / 0.3m
3.0' / 1.0m		0' / 0m			3.0' / 1.0m	

Units: Footcandles (top)/Lux (bottom)
 10.8 lux = 1 fc
 Measured on: All, reflectance model 80/50/20%
 Distance from surface: Bottom center of grid, 3' (1.0 m) from surface, light at a 45° angle off horizontal

CANDLE POWER DISTRIBUTION

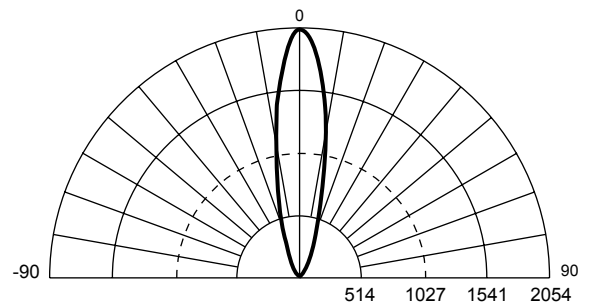

Measured on: White
 Beam center: 2054 cd
 Thin dashed lined: Indicates 50% of peak
 Multipliers: 0.32 Red, 0.53 Green, 0.17 Blue

ILLUMINANCE

COLOR	3' 1m	6' 2m	9' 3m	15' 5m
WHITE	225.0 2421.9	57.1 614.6	25.3 272.3	9.1 98.0
RED	72.05 775.0	18.3 196.7	8.1 87.1	2.9 31.3
GREEN	119.3 1283.6	30.3 325.8	13.4 144.3	4.8 51.9
BLUE	38.3 411.7	9.7 104.5	4.3 46.3	1.5 16.7

Measured in Footcandles (top)/Lux (bottom) on axis.
 Measured on: All, reflectance 0.

LIGHT OUTPUT

COLOR	TOTAL OUTPUT (lumens)	POWER (Watt)	EFFICACY (Lm/w)
WHITE	597	48.2	12.4
RED	191.0	16.6	11.5
GREEN	316.4	16.6	19.1
BLUE	101.5	16.6	6.1

COLORBLAST 12 TR

PHYSICAL DIMENSIONS

FRONT

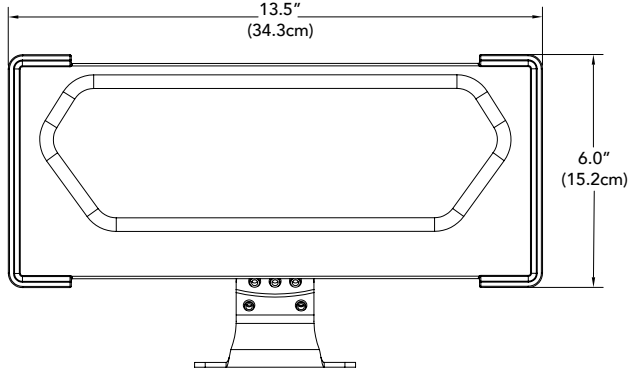

SIDE

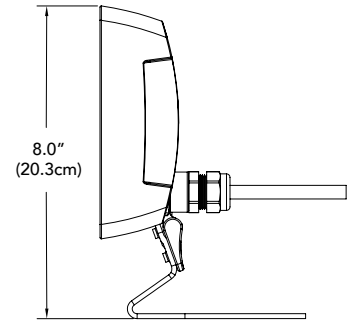

BASE

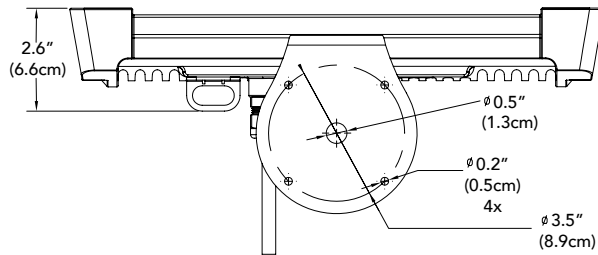

SIDE

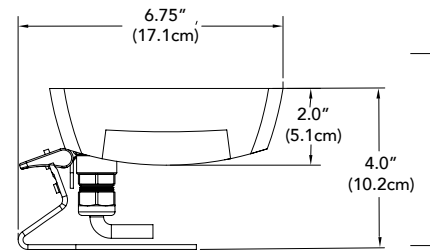

**ColorBlast 12 TR
ITEM# 116-000019-00**

POWER CONNECTION	3-wire, 18AWG power/data cable, 3-pin XLR connector
POWER REQUIREMENT	24VDC (50W)
WEIGHT RANGE	1.25 lbs. (0.6 kg) - 3 lbs. (1.3 kg)

OPTIBIN®

There are inherent variations in the fabrication processes of all semiconductor materials. For LEDs, this variance results in differences in the color and intensity of light output as well as electrical characteristics. Due to these differences, LED manufacturers sort production into "bins," but insuring the availability of a single bin is very difficult. To minimize this issue and achieve optimal color consistency in its products, Color Kinetics has developed and uses a proprietary technology called Optibin. Optibin is an advanced production binning optimization process that minimizes the effects of LED variance for the best possible output uniformity in the final product. Color Kinetics Optibin technology gives the most consistent control of color and intensity from product to product.

COLORBLAST 12 TR

FUNCTIONAL FLOW DIAGRAM

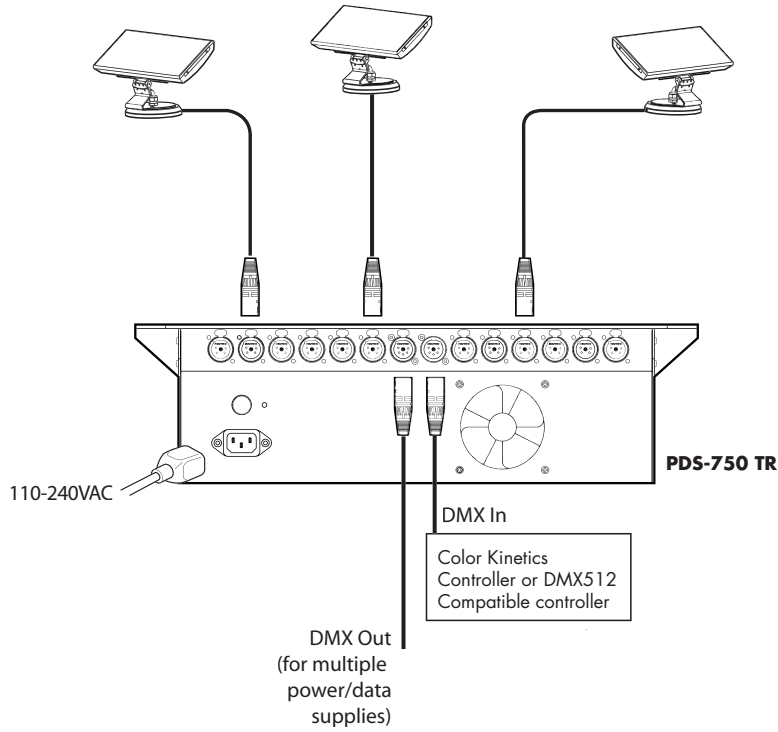

For complete installation instructions and safety precautions, refer to the ColorBlast 12 TR User Guide and wiring diagrams located on the web at: www.colorkinetics.com/support

□

Additional Items	
Power/Data Supply	PDS-750 TR (ITEM# 109-000019-00)
Controller	Any Color Kinetics controller or DMX512 compatible controller